

# TECHNICAL DATA SHEET FOR CENTRIFUGE MODEL LC10

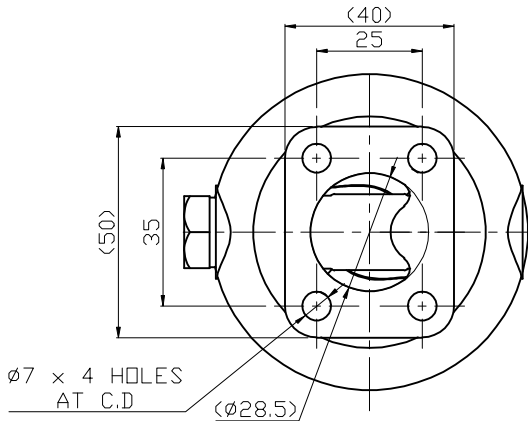

- SUITABLE FOR OIL SUMP CAPACITY 5 TO 14 LITRES.
- OIL INLET PIPE I.D ø6.0 mm MINIMUM
- OIL DRAIN PIPE I.D ø19 mm MINIMUM
- OIL INLET THREADS M12 X 1.5
- ROTOR VOLUME 0.6±0.05 LIT
- NET WEIGHT OF LC 10 IS 0.7±0.2 kg.
- DIRT HOLDING CAPACITY 75.0 Grams.

## MINIMUM HEIGHT FOR SERVICING

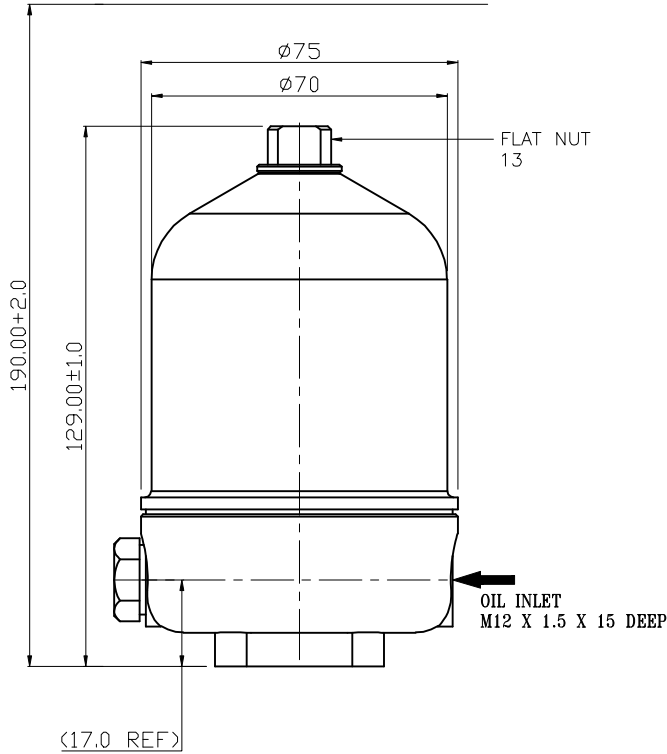

## PERFORMANCE DETAILS

Acceptance Limits -10%  
of Speed & Flow

PRESSURE (Kg/cm <sup>2</sup> )	FLOW (lpm)	SPEED (rpm)
3	1.86	4650
4	2.20	6000
5	2.57	7000

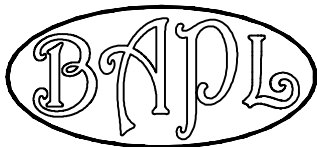

**BHAGYASHREE ACCESSORIES PVT.LTD.**

S.NO. 44/32, NARHE INDUSTRIAL AREA,  
NARHE, PUNE – 411 041.

Email : [marketing@baplpune.in](mailto:marketing@baplpune.in)

URL : [www.centrifugallubeoilcleaner.com](http://www.centrifugallubeoilcleaner.com)