

TECHNICAL DATA SHEET FOR CENTRIFUGE MODEL LC20

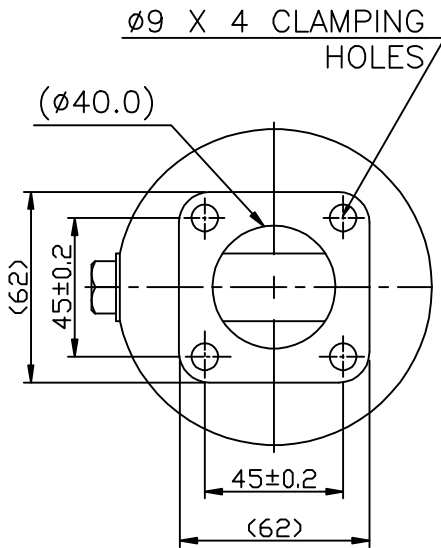

- SUITABLE FOR OIL SUMP CAPACITY 14 TO 30 LITRES.
- OIL INLET PIPE I.D $\phi 6.0$ mm MINIMUM
- OIL DRAIN PIPE I.D $\phi 20$ mm MINIMUM
- OIL INLET THREADS M12 X 1.5
- ROTOR VOLUME 0.20 Lit.
- NET WEIGHT OF LC 20 IS 1.25 ± 0.2 KG.
- DIRT HOLDING CAPACITY 150.0 Grams.

Minimum Height for Servicing

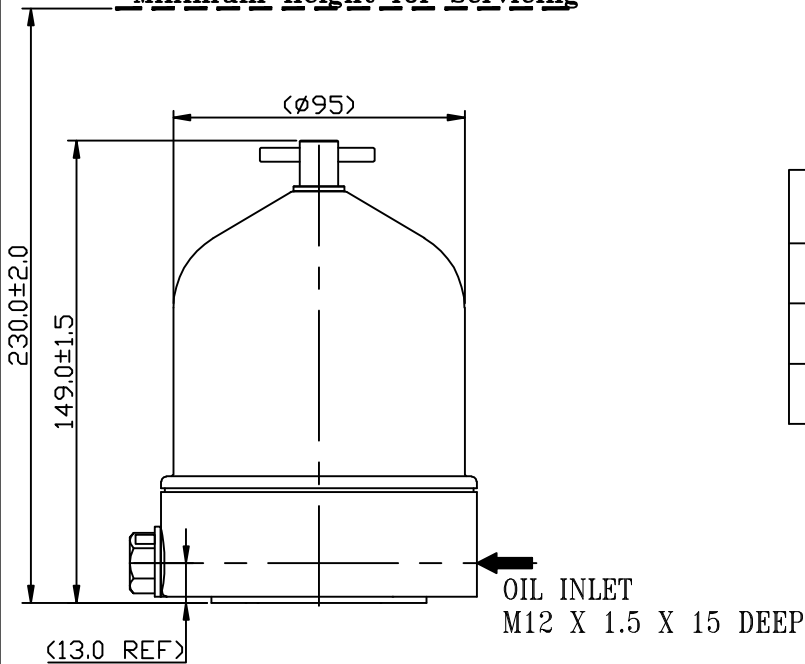

PERFORMANCE DETAILS

Acceptance Limits $\pm 10\%$
of Speed & Flow

PRESSURE (Kg/cm ²)	FLOW (lpm)	SPEED (rpm)
3	2.40	4800
4	2.85	5700
5	3.12	6300



BHAGYASHREE ACCESSORIES PVT.LTD.

S.NO. 44/32, NARHE INDUSTRIAL AREA,
NARHE, PUNE – 411 041.

Email : marketing@baplpune.in

URL : www.centrifugallubeoilcleaner.com