

# TECHNICAL DATA SHEET FOR CENTRIFUGE MODEL LC200

## INSTALLATION DIMENSIONS

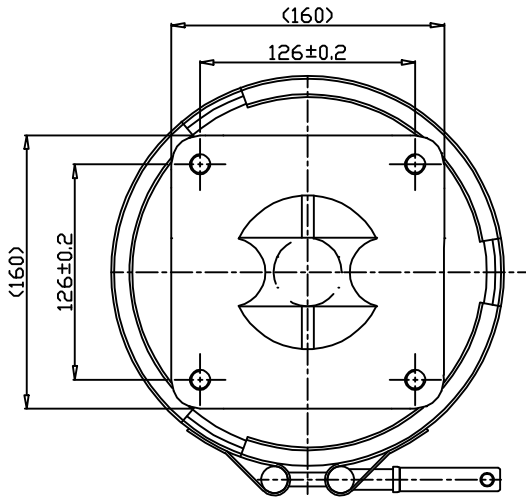

- SUITABLE FOR OIL SUMP CAPACITY 200 TO 400 LITRES.
- OIL INLET PIPE I.D  $\phi$ 12.7 mm MINIMUM
- OIL DRAIN PIPE I.D  $\phi$ 50 mm MINIMUM
- OIL INLET THREADS 1/2" BSP
- ROTOR VOLUME 2.0±0.05 LIT
- NET WEIGHT OF LC 200 IS 14.5±0.2 KG.
- DIRT HOLDING CAPACITY 2 Kg.

## MINIMUM HEIGHT FOR ROTOR REMOVAL

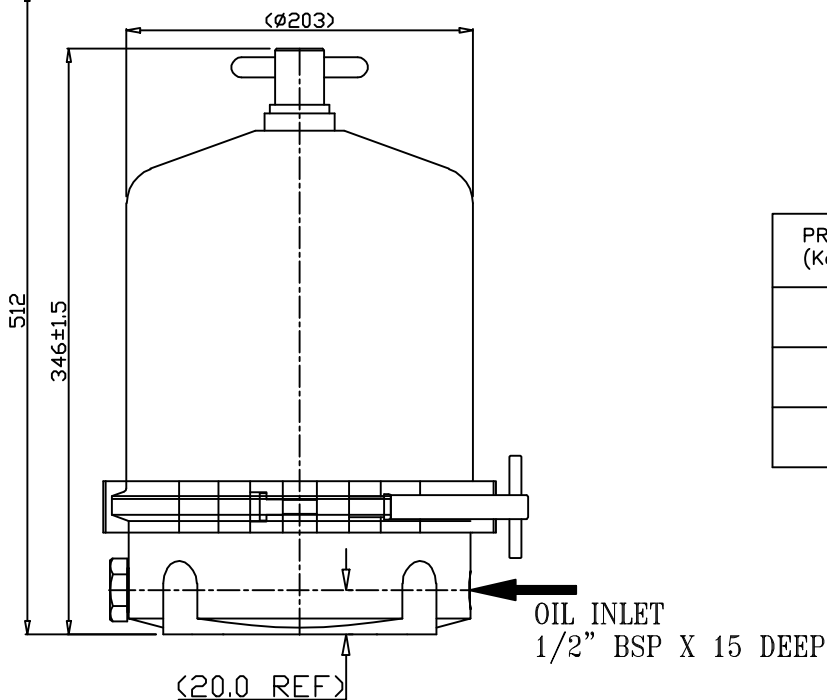

## PERFORMANCE DETAILS

Acceptance Limits  $\pm$ 10%  
of Speed & Flow

PRESSURE (Kg/cm <sup>2</sup> )	FLOW (lpm)	SPEED (rpm)
3	17	2500
4	21.80	3200
5	25.00	3800

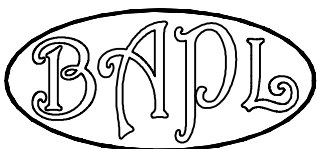

**BHAGYASHREE ACCESSORIES PVT.LTD.**

S.NO. 44/32, NARHE INDUSTRIAL AREA,  
NARHE, PUNE – 411 041.

Email : [marketing@baplpune.in](mailto:marketing@baplpune.in)

URL : [www.centrifugallubeoilcleaner.com](http://www.centrifugallubeoilcleaner.com)