

TECHNICAL DATA SHEET FOR CENTRIFUGE MODEL LC50

MOUNTING DIMENSIONS

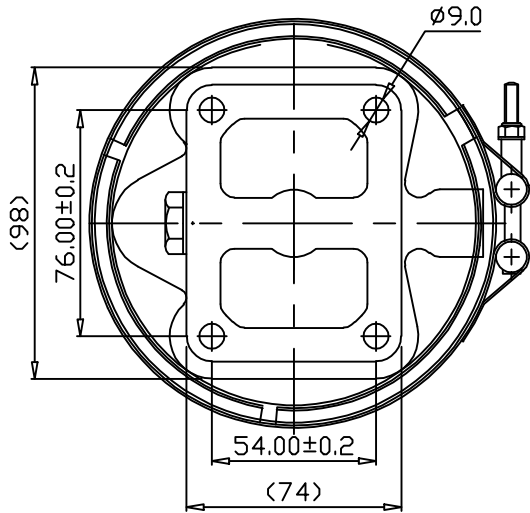

- SUITABLE FOR OIL SUMP CAPACITY 40 TO 65 LITRES.
- OIL INLET PIPE I.D Ø8.0 mm MINIMUM
- OIL DRAIN PIPE I.D Ø30 mm MINIMUM
- OIL INLET THREADS M16 X 1.5
- ROTOR VOLUME 0.5±0.05 LIT
- NET WEIGHT OF LC 50 IS 2.5±0.2 KG.
- DIRT HOLDING CAPACITY = 400.0 Grams

MINIMUM CLEARANCE FOR EASE OF SERVICING

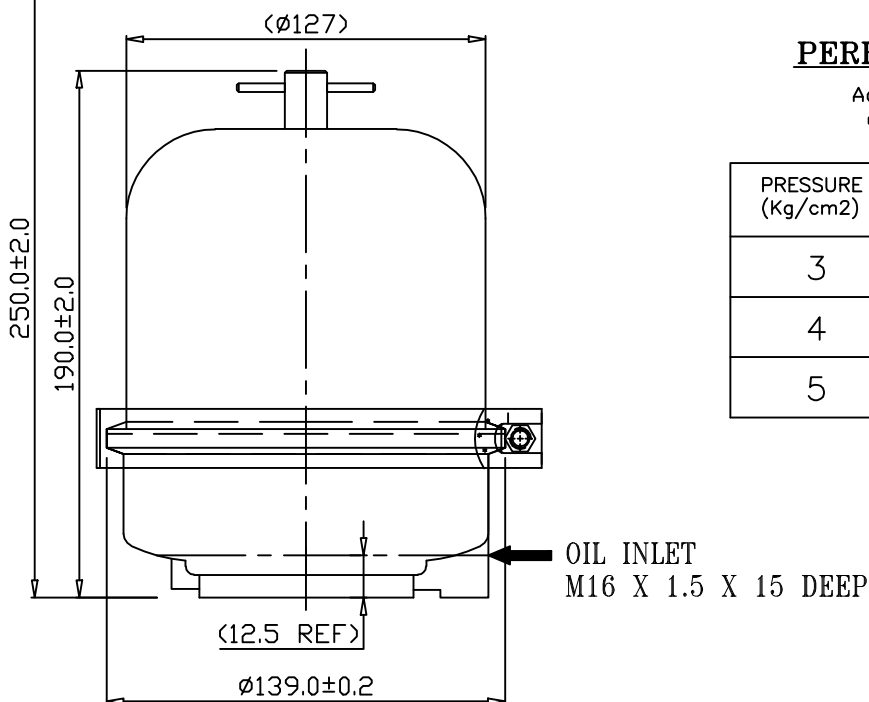

PERFORMANCE DETAILS

Acceptance Limits ±10% of Speed & Flow

PRESSURE (Kg/cm ²)	FLOW (lpm)	SPEED (rpm)
3	4.07	4600
4	4.65	5400
5	5.50	6200



BHAGYASHREE ACCESSORIES PVT.LTD.

S.NO. 44/32, NARHE INDUSTRIAL AREA,
NARHE, PUNE – 411 041.

Email : marketing@baplpune.in

URL : www.centrifugallubeoilcleaner.com