

TECHNICAL DATA SHEET FOR CENTRIFUGE MODEL LC60

MOUNTING DIMENSIONS

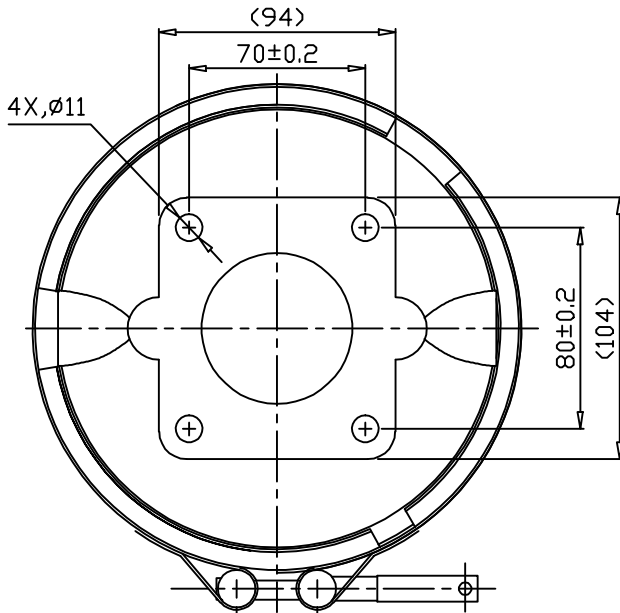

- SUITABLE FOR OIL SUMP CAPACITY UPTO 100 LITRES.
- OIL INLET PIPE I.D Ø9.5 mm MINIMUM
- OIL DRAIN PIPE I.D Ø38 mm MINIMUM
- OIL INLET THREADS M16x1.5
- ROTOR VOLUME 0.6±0.05 LIT
- NET WEIGHT OF LC 60 IS 3.5±0.2 KG.
- DIRT HOLDING CAPACITY 600.0 Grams.

MINIMUM HEIGHT FOR EASE OF SERVICING

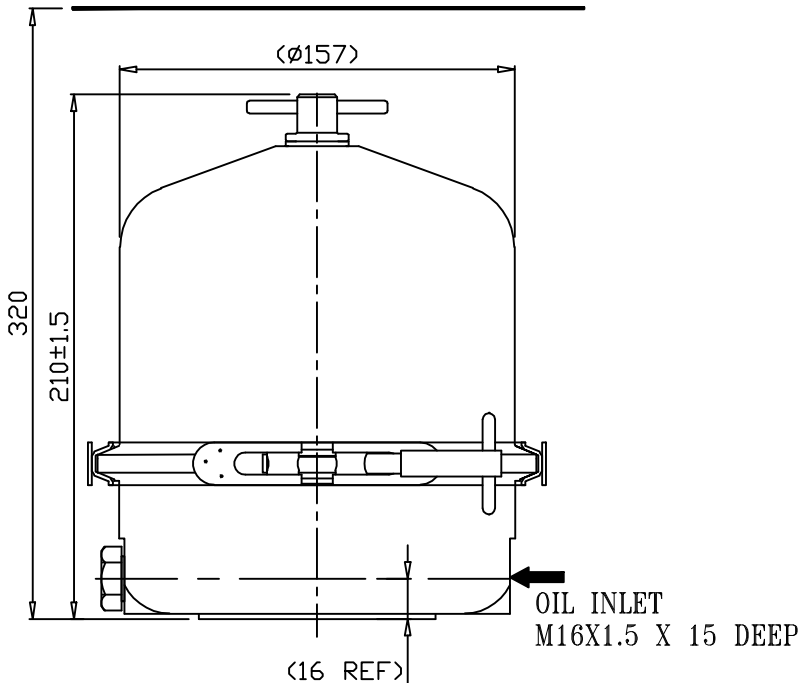

PERFORMANCE DETAILS

Acceptance Limits ±10%
of Speed & Flow

PRESSURE (Kg/cm ²)	FLOW (lpm)	SPEED (rpm)
5	8.67	6750
6	9.50	7200
7	10.40	7700

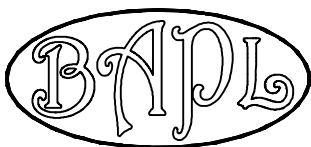

BHAGYASHREE ACCESSORIES PVT.LTD.
 S.NO. 44/32, NARHE INDUSTRIAL AREA,
 NARHE, PUNE – 411 041.
 Email : marketing@baplpune.in
 URL : www.centrifugallubeoilcleaner.com